

# HL150-3- 400V-SF

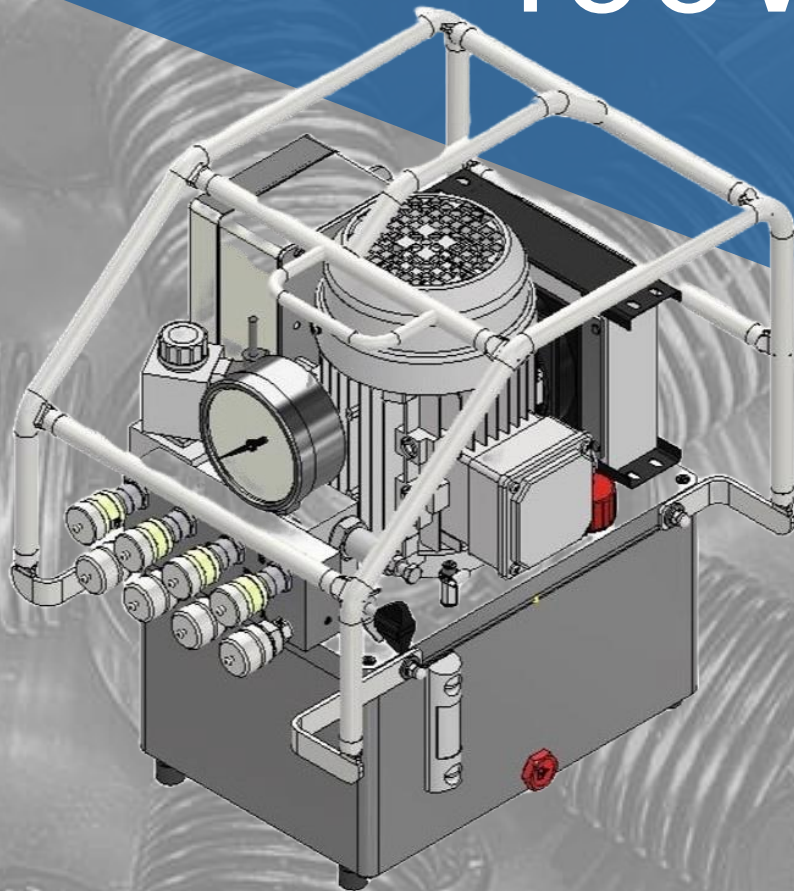

Maximum Pressure	10,145 PSI	700 bar
Voltage	3~400 V 50Hz	3~400 V 50Hz
Nominal Power output	2.04 HP	1,5 kW
5m remote control with electric push button		
<b>Pump Capacity</b>		
Low pressure < 75 bar    1087 PSI	726 in <sup>3</sup> /min	11,9 l/min
Medium pressure 75-220 bar    3188 PSI	250 in <sup>3</sup> /min	4,1 l/min
High pressure up to 680 bar    9855 PSI	104 in <sup>3</sup> /min	1,7 l/min
Connections	1-/2-/4-Port	1-/2-/4-Port
Weight without/with oil	70 / 90 lbs	32 / 41 kg
Fluid capacity	2.4 gal	9,0 Liter
Fluid DIN 51524-2	HLP32 or HLP46	HLP32 or HLP46
<b>Dimensions</b>		
Length	18"	46 cm
Width	14"	35 cm
Height	20"	51 cm
Noise Level	82 dB(a)	82 dB(a)